



INSTALLATION GUIDE

PERFORMANCE. DELIVERED.

For Support Please Call: 216.663.8830

Hours: M-F: 8:00am - 5:00pm

or visit us at: www.humongousfan.com



DO NOT DISCARD THIS DOCUMENT: SAVE FOR FUTURE USE

Table of Contents

Table of contents.....	1
Before you begin	2
Safety Information.....	3
Pre-Install Checklist.....	4
Parts Checklist.....	5
Parts Checklist Cont'd.....	6
Technical Specifications.....	7
Performance, Placement, and Clearances.....	8
Installing the VFD Controller and Preparing Conduit.....	9
Maximum Length of Cable Runs	10
Open/Bar-Joist Standard Mounting	11
Open/Bar-Joist Standard Mounting Cont'd	12
Open/Bar-Joist Mounting with Extension Kit.....	13
I-Beam Mounting with Extension Kit.....	14
I-Beam Mounting with Extension Kit Cont'd.....	15
I-Beam Mounting with Extension Kit Cont'd.....	16
Safety Cable & Guy wire Routing.....	17
Remove Breather Plug.....	17
Connect Motor Leads	18
Motor Rotation Direction	19
Blade Installation.....	20
First Time Startup & Operation.....	22
Fan Maintenance.....	22
Troubleshooting & Frequency Asked Questions (FAQ)	23
Troubleshooting & Frequency Asked Questions (FAQ) Cont'd.....	24
VFD Controller Fault Codes.....	25
Warranty Information.....	26
Notes.....	27

THANK YOU!

AND CONGRATULATIONS ON YOUR NEW HVLS FANS.

Before you begin, please read the important info below:

Your shipment should appear like this when it arrives

One Fan:



Two Fans:



Inspect packaging for external damage.

Photograph and document irregularities and mark any large damage before signing and accepting your order.

Report any damage claims within 48 hours.

Claims are much more likely to succeed the sooner they are made!

Safety Information



CAUTIONS help you avoid issues during installation & use.



WARNINGS are designed to protect your safety and that of your product.



Disconnect all power at the source before attempting servicing or cleaning. Use lock-out and tag-out procedures to prevent the inadvertent reapplication of power during this process.



Installation to be done by state certified electricians and contractors familiar with local and national codes. This is the owner's responsibility. Failure to do so may result in damage to property or personnel.



Damage will be done to the controller by misconnection of input and output wiring. Destruction of controller due to miswiring is not covered by warranty.



Safety devices removed during maintenance must be properly reinstalled prior to reapplying power to the fan or controller.



High voltages drive this product. Always disconnect and lock out all power sources prior to accessing internal components of the fan or its controller.



All VFD parameters have been pre-set by the manufacturer. Do not change any of these settings without first consulting the factory.

Pre-Install Checklist

Hardware

- Ensure that the Controller you have received is rated for the same supply voltage and number of phases as listed on your order confirmation. Rating information is provided on the box of the unit. If your hardware is different, do not install. Contact the manufacturer.
.....
- Ensure that the gearbox assembly is configured for the proper voltage setting (refer to page 4) and that the terminal leads are in good condition.
.....
- Ensure the distance from the Humongous Fan to the controller is within the maximum distance as stated in this manual (see page 7.)
.....
- Ensure no components have been separated, lost, or damaged in shipment, or else **immediately report damage to the manufacturer and freight carrier.**
.....
- Has your contractor or facility manager approved of the mounting scenario which you intend for your installation?
.....

Obstructions

- Overhead Clearance: Will the Humongous Fan be installed such that it will meet the OSHA standard that the blades are a minimum of 10 ft. or more from floor level?
.....
- Horizontal Clearance: Will the Humongous Fan be installed such that any obstructions are 2 feet or more, horizontally, from the tips of the blades.
.....
.....
- Vertical Clearance: Will the Humongous Fan be installed such that it will meet the minimum clearances to the ceiling deck, as stated in table 1.
.....
- Direct Winds: Ensure that the fan will not be subject to direct, high winds. Powerful gusts or strong, sustained winds pose a potential threat to the blades. **Humongous Fans are designed for indoor use. Refer to additional tethering detail on page 'x' for installation at outdoor, under canopy use.**

Parts Checklist

Tools required to carry out installation of Humongous Fan:

- (1) 9/16" wrench
- (1) 9/16" socket
- (1) 3/4" Wrench
- (1) 3/4" Socket
- (1) 3/8" Socket
- (1) Torque wrench
- (1) Level (< 24")
- (1) 3/16" Allen key
- (1) 10 mm Wrench

Standard Hardware Components, per fan:

- (1) Motor Powerhead Assembly
- (1) VFD controller
- (1) Set of 8 Humongous Fan Blades
- (1) 10' Length of 1/8" Galvanized Steel Cable
- (2) 1/8" Cable Clamps
- (16) 1/4"- 20 x 1-1/4" Grade 8 UNC Serrated Head Flange Bolts.

****OPTIONAL** 2', 3', 6', or 10' Mounting Extension Kit** includes:

- 1/4" Steel Plate for 3' or 6' Mounting Extension Kit:
- (1) Upper Yoke Weldment
- (1) 3' or 6' steel Extension Tube
- (2) Beam Clamps
- (1) 10' Safety Cable
- (4) 10' Guy Wires
- (10) 1/8" Cable Clamps
- (4) Turnbuckles
- (8) Thimbles

Installation Hardware Kit:

- (4) 3/8-16 x 1-3/4" Grade 8 Hex Head Cap Screw
- (4) 3/8-16 Grade 8 Nylon Lock Nut
- (3) 1/2 - 13 x 4-1/2" Grade 8 Hex Head Cap Screw
- (3) 1/2 - 13 Grade 8 Nylon Lock Nut
- (6) 1/2" Flat Washers

Parts Checklist (continued)

****OPTIONAL** 1" Mounting Extension Kit** includes:

- 1/4" Steel Plate for 1" Mounting Extension Kit:
- (1) Upper Yoke Weldment
- (1) 10" steel Extension Tube
- (2) Beam Clamps
- (1) 10' Safety Cable
- (2) 1/8" Cable Clamps

Installation Hardware Kit:

- (4) 3/8-16 x 1-3/4" Grade 8 Hex Head Cap Screw
- (4) 3/8-16 Grade 8 Nylon Lock Nut
- (3) 1/2 - 13 x 4-1/2" Grade 8 Hex Head Cap Screw
- (3) 1/2 - 13 Grade 8 Nylon Lock Nut
- (6) 1/2" Flat Washers

Technical Specifications

Diameter (D)	Motor Size	Minimum Required Supply Circuit	Nominal Output Voltage	Input Power	Max Output RPM	Minimum Clearance to Ceiling Deck (F)	Minimum Horizontal Clearance (E)
8'	1/2 HP (0.375 kWh)	110-115V 1P: 15A 208-240V 1P: 10A 208-240V 3P: 10A 460-480V 3P: 10A	230V 230V 230V 460V	13 A 6.4 A 3.7 A 1.85 A	44	3'-4'	2 ft.
12'	1/2 HP (0.375 kWh)	110-115V 1P: 15A 208-240V 1P: 10A 208-240V 3P: 10A 460-480V 3P: 10A	230V 230V 230V 460V	13 A 6.4 A 3.7 A 1.85 A	44	3'-4'	2 ft.
16'	1/2 HP (0.375 kWh)	110-115V 1P: 15A 208-240V 1P: 10A 208-240V 3P: 10A 460-480V 3P: 10A	230V 230V 230V 460V	13 A 6.4 A 3.7 A 1.85 A	44	3'-4'	2 ft.
20'	1 1/2 HP (1.119 kWh)	208-240V 1P: 10A 208-240V 3P: 10A 460-480V 3P: 10A	230V 230V 460V	12.3 A 7.12 A 3.5 A	49	4'-6'	2 ft.
24'	3 HP (2.24 kWh)	208-240V 3P: 12A 460-480V 3P: 6A	230V 460V	12 A 6 A	<u>62</u>	6'-8'	2 ft.

Table 1 - Weights and Clearances

Performance, Placement, and Clearances

Fan placement is critical to ensuring optimal performance. Be certain that all minimum clearances are met when determining the placement for your fan (Column "E" in Table 1.)

Fans must be installed in areas free of any obstructions i.e., light fixtures, sprinklers, overhead piping, HVAC equipment, crane systems, and conduit & wiring.

If installing more than one fan near each other, each fan must be installed no less than 2.5x the fan diameter.

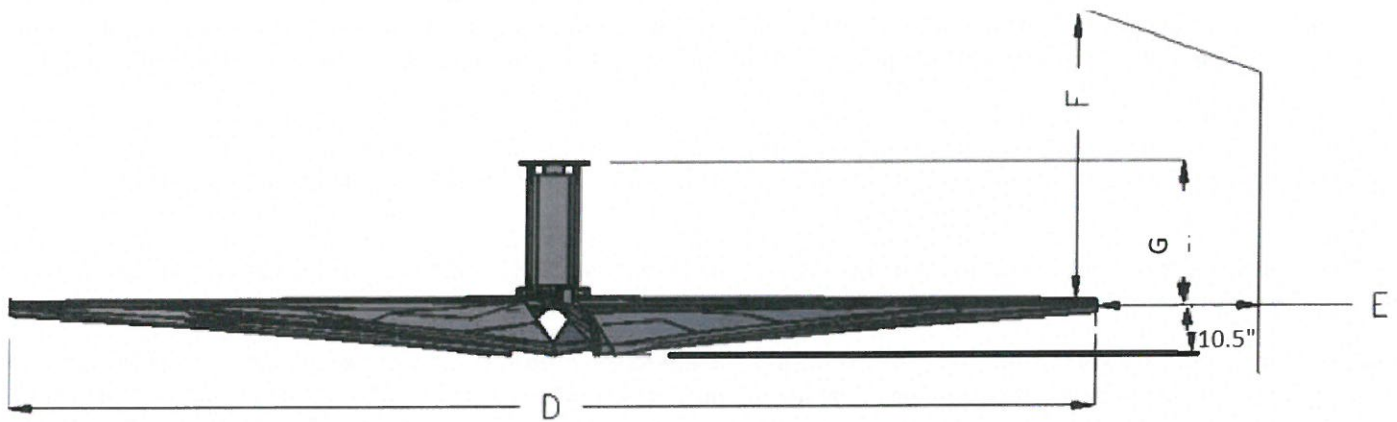

Figure 1 – Fan Dimensions & Clearance Requirements

For standard frame, G is 23 ½ "

Diameter (D)	G
8'	19"
12'	19"
16'	19"
20'	28"
24'	28"

□ STEP 1



Installing the VFD Controller and Preparing Conduit

Electrical installation will be done before installing fan hardware in almost all cases.

Number of incoming wires required by the customer will vary depending on whether the motor rated for single phase (1 ϕ) or three phase (3 ϕ) input.

See **Table 1** for the circuit protection. Refer to the latest edition of the National Electrical Code (NEC) to determine the proper wire size necessary for the installation while also following all local codes & jurisdictions for this installation.

Connection between the VFD controller and the fan motor will be 4 wires: three leads and one ground.

-  Regardless of whether the input voltage is 1 ϕ or 3 ϕ , the power to the fan motor will always be 3 ϕ . See **Figure 3** below.
-  Power input current is not the same as output current to the motor. Input current will always be more than the output. Depending on the number of phases, input current may be much more than the output current. See **Table 1** for fan sizes to determine the minimum supply circuit required.

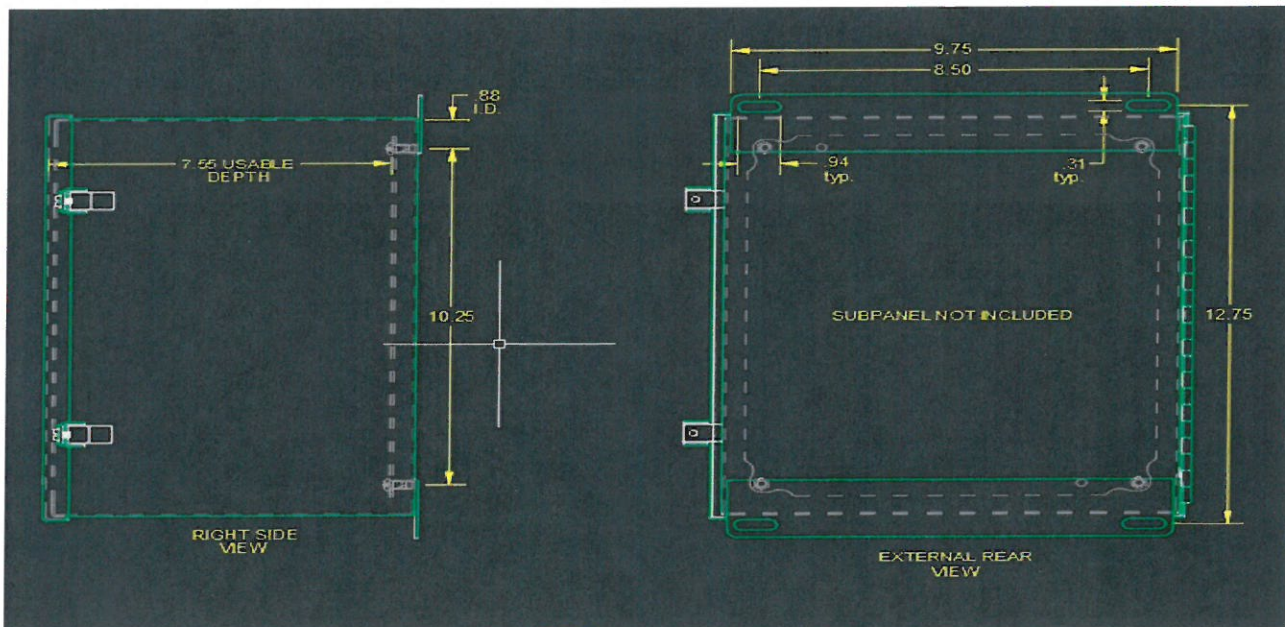

Figure2 – VFD Controller for 1/2 horsepower motor

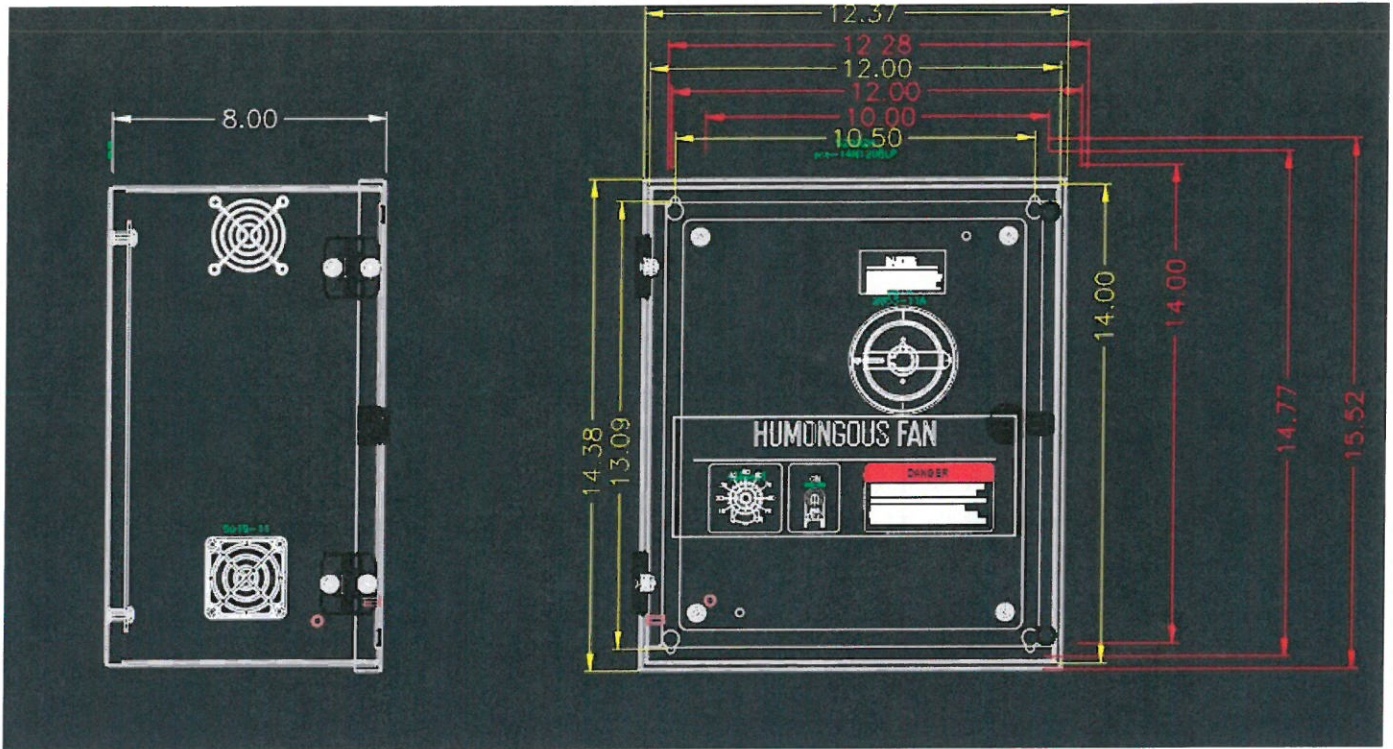

Figure 2a – VFD Controller for 1 ½ horsepower motor and 3 horsepower motor

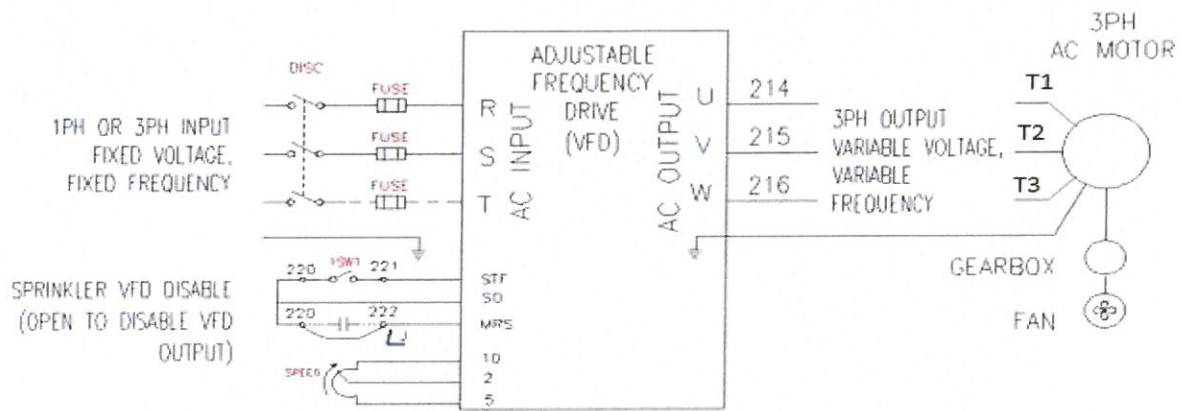

Figure 3 – Variable Frequency Drive (VFD) Input / Output Connections

Maximum Length of Cable Runs

Please Review and understand the Maximum Cable runs associated with the size of your Controller and the type of power that will be supplying this system.

It is crucial to the selection and proper functioning of the fan that these limits are observed.

If you have any questions or need more information, please call the factory for technical support before wiring.

Motor Size	Power Supply Circuit	Maximum Cable Run from Controller to motor (all wire lengths)
1/2 HP (0.375kW)	110-115v 1ph	650'
	208-240v 1ph	650'
	208-240v 3ph	650'
	460-480v 3ph	328'
1 1/2 HP (0.75kW)	208-240v 1ph	980'
	208-240v 3ph	980'
	460-480v 3ph	328'
3 HP (2.24 kW)	208-240v 3ph	1640'
	380-480v 3ph	980'

STEP 2a

Open/Bar-Joist Standard Mount

 Before attempting any fan installation, consult and verify with a structural engineer that the existing structure is sufficient and capable of supporting the loads of the fan.

 The integrity of the mounting is the responsibility of the owner/installer alone and not Humongous Fan.

In general, mounting a Humongous Fan between Joists is easier than clamping to a beam, especially if the joists are close together. Furthermore, this type of mounting offers flexibility in fitting the fan between lights and avoiding the potential for shadows cast by the fan blades passing under the light source.

Support materials, including hardware to mount the support materials are not provided with the fan. Use of PowerStrut™ (or equivalent) products is encouraged as it can speed installation time and limit the weight of steel to be installed overhead. Wider spans will require heavier materials. Please refer to [Table 4](#) for specific details.

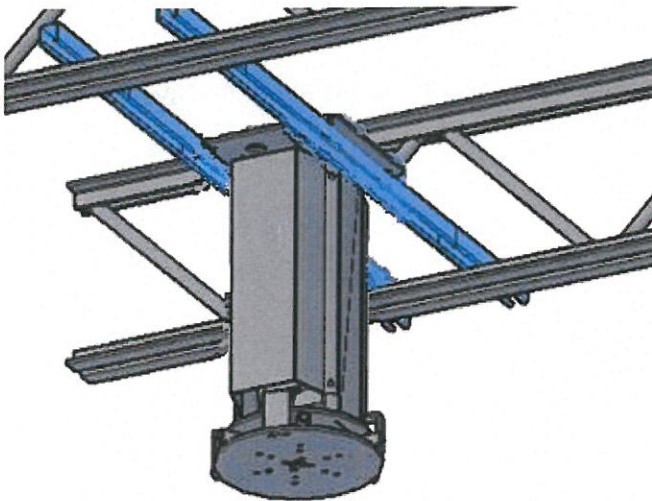





Figure 4 - Mounting Across Joists

Span	Acceptable Materials
6' or Less	2-1/2" x 2-1/2" x 1/4" Angle Iron
	Powerstrut' PS210 or equal (d 24')
8' or Less	3" x 3" x 1/4" Angle Iron
10' or Less	3-1/2" x 3-1/2" x 1/4" Angle Iron
	Powerstrut' PS200-2t3 or equal
12' or Less	3" x 3" x 1/4" Square Tube
	4" x 4" x 1/4" Angle Iron
Above 12'	Contact Factory

Table 4 - Required Support Materials

Product	Torque (Ft-Lb)	Torque (N-M)
1/4-20 UNC Grade 8 Bolts	9	12
5/16-18 Cable Clamp Nuts	19	26
3/8-16 UNC Grade 8 Bolts	33	44.7
1/2-13 UNC Grade 8 Bolts	78	106

Table 5 - Required Torque Values

-  The safety cable must be routed between the legs of the gearmotor base and over the support material as shown and must be secured with the two (2) cable clamps provided.
-  The mounting must be sufficiently secure to absorb 250 ft-lbs (340 nt-m) of torque, plus an appropriate safety factor. All bolts must be torqued to the values in [Table 5](#).
-  The baseplate must be secured to material with (4) 3/8-16 Grade 8 bolts, spaced 10" apart.
-  The integrity of the mounting is the responsibility of the owner/installer alone and not Humongous Fan.

STEP 2b

Open/Bar-Joist with Extension Kit

If using structural iron or strut to support the fan, the structural iron should be drilled and bolted directly to the mounting base plate. The beam clamps are intended to be used only when mounting directly to a wide flanged beam (I-beam).

1. Drill and mount the support materials according to Figure below, using appropriate hardware as directed in [Tables 4 and 5](#).
2. Attach and secure the steel down rod and powerhead assembly using the factory provided hardware following the process detailed under **Step 2a**.

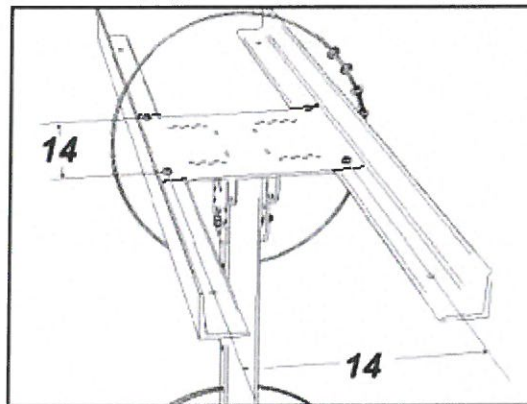

Figure X – Open/Bar joist mounting with extension

□ STEP 2b

I-Beam Mounting with Extension Kit

****Note** The I-beam must be part of the existing structure to install the Humongous Fan! Do not directly mount the Humongous Fan to an I-beam!**

For beam mount scenarios, it is normally necessary to purchase a Mounting Extension Kit, which is sold separately. The beam mounting kit allows you to install the fan on a sloped beam while ensuring the motor and mounting extension kit remains vertical and the blades remain parallel to the floor. The weldment allows the fan to clamp directly to a beam with a flange with between 7" and 15".

Only use the beam clamps provided with the Beam Mounting Kit. Any attempt to use different fastening methods will invalidate your warranty.

Angle Adjustment

The weldment is capable of adjusting for angles up to 30 degrees from horizontal. This capability must not be used to mount the fan in any shaft orientation other than vertical.

Installation

Determine the flange width of the I-beam and ensure the top plate of the Humongous Fan assembly fits within the dimensions of the I-beam flange width. See [Figure 5](#) for top plate dimensions.

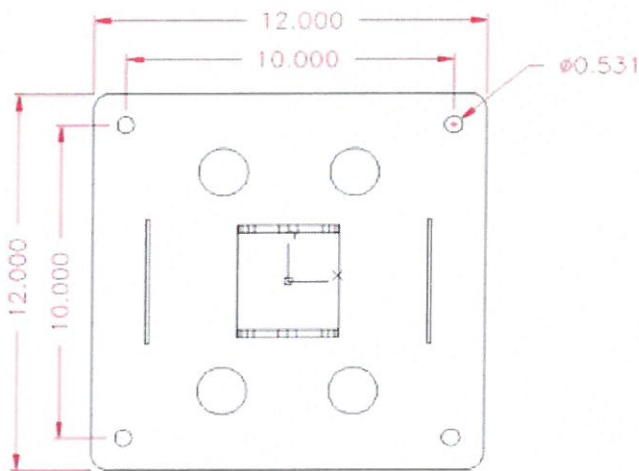

Figure 5 - Top Plate Dimensions, Motor Frame

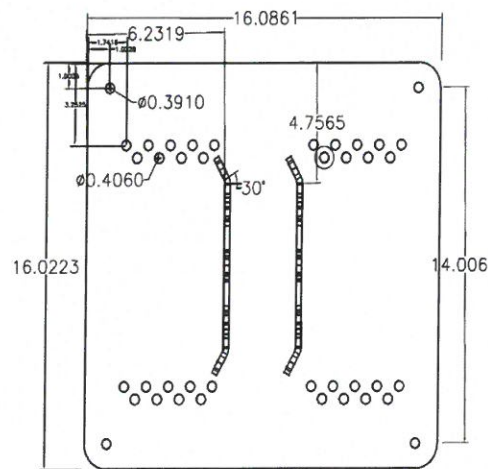

Figure 5a, Mounting Ext Base Top Plate

1. The mounting weldment should be mounted to the beam using the (2) beam clamps, (4) 3/8-16 x 1-3/4" Grade 8 HHCS and the Grade 8 Nylon Lock Nuts.



Ensure that the narrowest possible set of mounting holes is used on the upper yoke. This maximizes the engagement between the beam clamp and the beam. It is not necessary that the beam mount be exactly centered under the beam. The bolts must be installed using the provided lock washers and torqued to the appropriate values called out in [Table 5](#).

2. Attach and fasten the steel downrod using (2) 1/2-13 x 4-1/2" Grade 8 HHCS, (2) 1/2-13 Grade 8 Nylon Lock Nuts and (4) 1/2" flat washers. Secure as show in [Figure 7](#).
3. Fasten the powerhead assembly to the steel downrod using (1) 1/2-13 x 4-1/2" Grade 8 HHCS, (1) 1/2-13 Grade 8 Nylon Lock Nut and (2) 1/2" Flat washers. Secure the second safety cable, as shown in [Figure 8](#).

Optional mounting extension kit hardware package includes the following. If any items are missing or damaged contact the factory for replacement.

- | | |
|---|---|
| <input type="checkbox"/> (1) upper Yoke Weldments | <input type="checkbox"/> (4) 3/8-16x1-3/4" G.8 HHCS |
| <input type="checkbox"/> (1) 3' or 6' Steel Extension Tube | <input type="checkbox"/> (4) 3/8-16 G. 8 Nylon Lock Nut |
| <input type="checkbox"/> (2) Beam Clamps | <input type="checkbox"/> (3) 1/2-13 G. 8 Nylon Lock Nut |
| <input type="checkbox"/> (4) 10' Guy Wires | <input type="checkbox"/> (3) 1/2-13 x 4-1/2" G.8 HHCS |
| <input type="checkbox"/> (1) 10' of 1/8" Galv. Safety Cable | <input type="checkbox"/> (6) 1/2" Flat Washers |
| <input type="checkbox"/> (10) 1/8" Cable Clamps | |
| <input type="checkbox"/> (4) Turnbuckles | |
| <input type="checkbox"/> (8) Thimbles | |

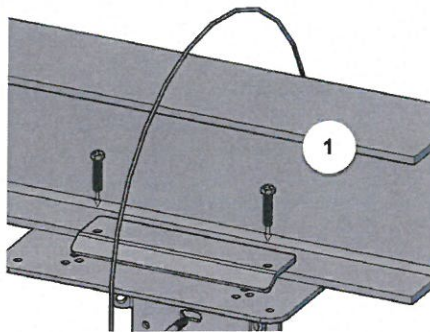

Figure 6a - Weldment secured with beam clamps.

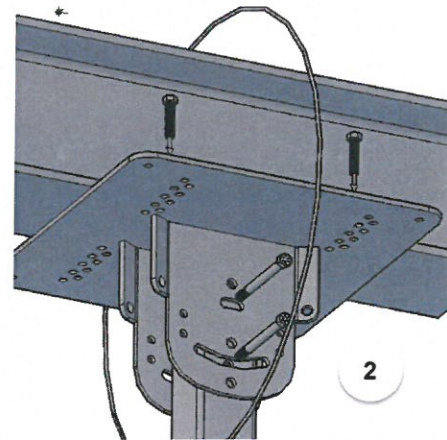

Figure 6b - Attaching Steel Downrod

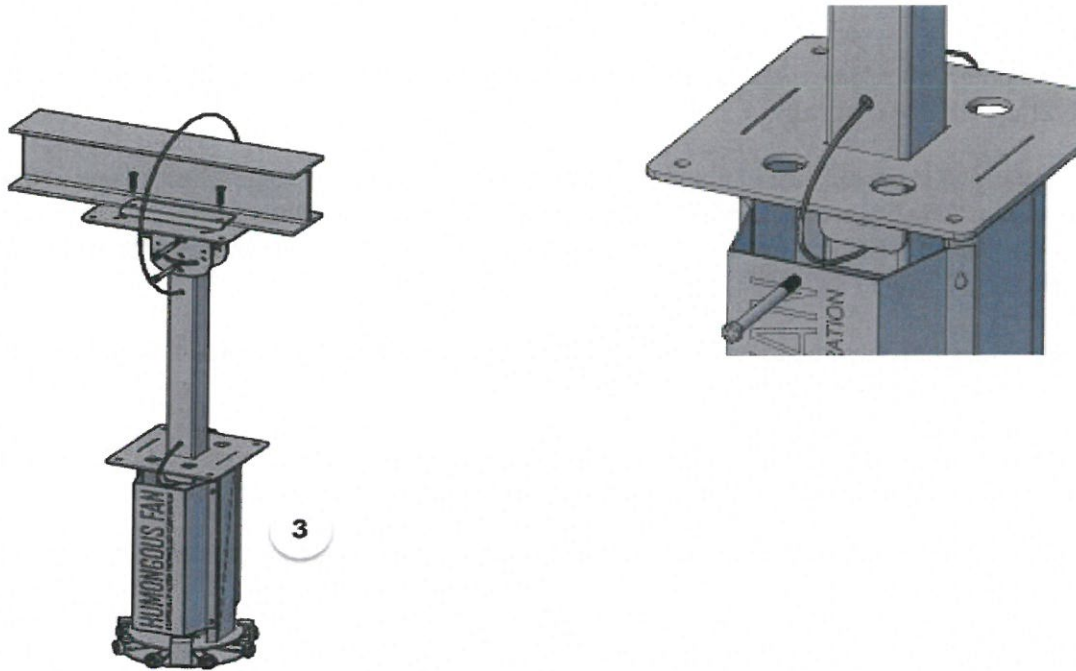

Figure 6c - Attaching the Powerhead Assembly

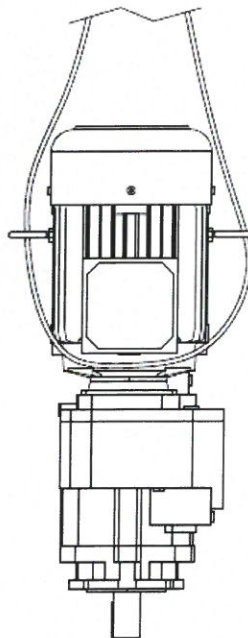

Figure 6e - Safety cable through the motor frame & eye loops (1-1/2 and 3hp only)

STEP 3

Safety Cable & Guy Wire Routing

Ensure that the safety cable is installed with both cable clamps. The cable clamps should be installed, 1 each on the turnback of each end of the cable as shown below and torqued to the value listed in [Table 2](#).

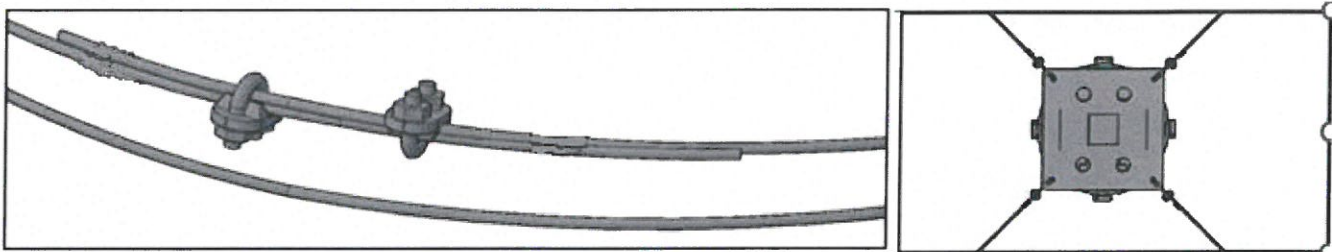

Figure 7 – Detail of safety cable clamps

The safety cable must be looped between the legs of the fan/hub assembly and through the 3/8" diameter hole near the bottom of the downrod as shown on the drawing in [Figure 6c](#). As before, the cable clamps must be torqued to the proper value as listed in [Table 1](#).

Figure 8 – Detail of guy wire configuration viewed from above the powerhead assembly

STEP 4

Remove the Breather Plug

Once the fan hub is installed, the user must remove the black plastic breather plug from its brass fitting as shown in [Figure 9](#). Once the breather plug is removed, you may not move the fan without replacing the plug. If the motor must be removed from the ceiling the breather plug must always be re-inserted. Failure to reinsert the breather plug will result in gearbox oil draining from the unit.

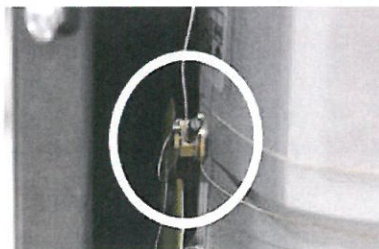

Figure 9 – Breather plug insert

□ STEP 5

Connect Motor Terminal Leads

This step should have been performed at the factory. However, if the internal connections have been disturbed this will provide the configuration for the voltage to be supplied to the motor.

Once the fan motor/hub assembly is installed, electrical installation can proceed. Do not attempt to install fan blades until the electrical installation is complete and the system is tested.

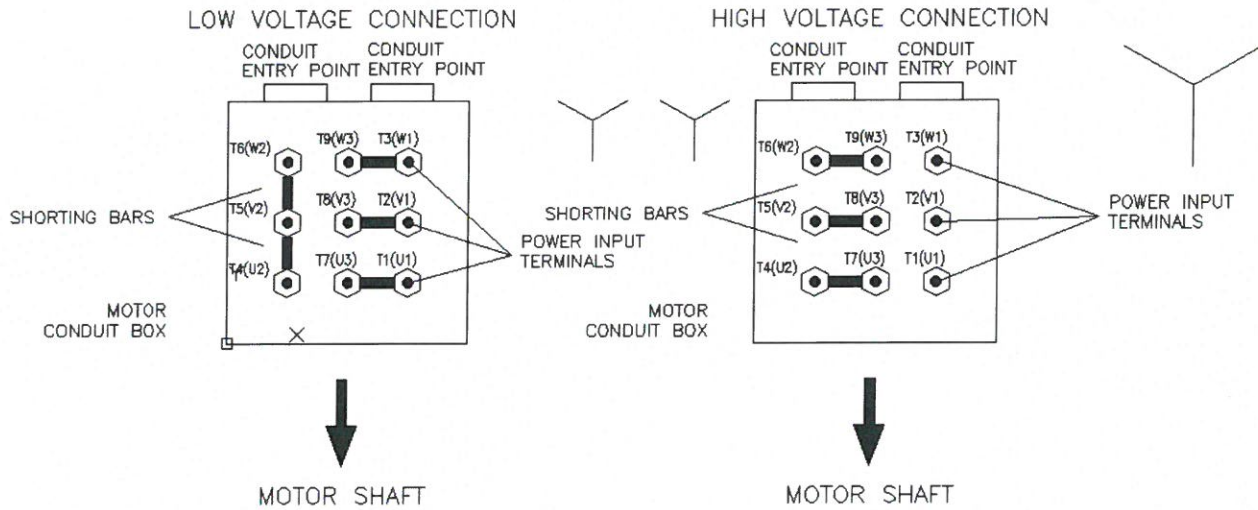

Figure 10 – Gearmotor terminal connections

□ STEP 6

Check the Motor Rotation Direction

1. Double-check the installation before applying power to prevent costly damage due to incorrect wiring. Do NOT turn on the power at the power distribution panel at this time.
2. Turn the speed potentiometer (on the door) fully counter-clockwise for minimum speed.
3. Place the ON-OFF toggle switch in the OFF position.
4. With the enclosure door open, twist the red disconnect handle (in the upper right portion of the panel) clockwise. No lights or signs of power should be visible.
5. Turn on the power at the distribution panel. The VFD will display "0.00". The indicators for Hz, MON, and EXT will also be illuminated.
6. Place the ON-OFF switch in the ON position.
7. Slowly turn the Potentiometer clockwise until you see approximately 5.00 hz on the display.
8. Observe the fan hub rotation for counter-clockwise rotation when viewed from underneath.
9. If the fan hub rotates in the clockwise direction, put the ON-OFF switch in the OFF position, disconnect and lock out power at the distribution panel. Now switch any two of the motor leads at the terminal block, 214, 215 or 216.
10. Turn on the power at the distribution panel and put the ON-OFF switch in the ON position. The fan hub should now turn in the counter-clockwise direction.
11. After confirming correct rotation, turn off and lock out the power at the distribution panel. Installation of the blades may now proceed.

□ STEP 7

Blade Installation

Once the electrical installation is completed and tested, the blades can be installed. The blade has a solid spar which is tapped to accept two ¼-20 bolts each.

- ⚠ Ensure that the slots in the collar and in the tubes of the blade hub are aligned as shown in the diagram at the left.
- ⚠ Be certain that the Allen key slot faces the floor before installing the blades. If they are not, you will not be able to reach them after the blades are installed.

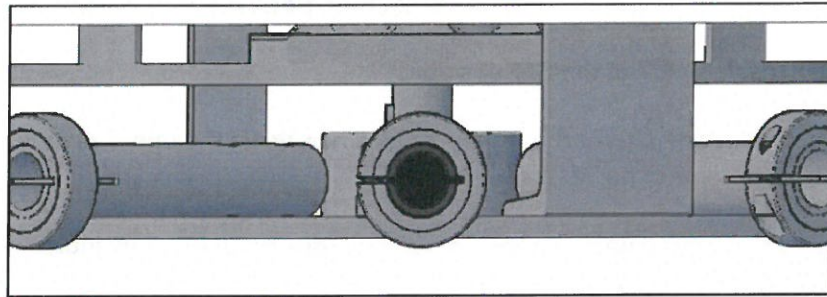

Figure 11 – Blade Locking Collar Alignment

The spars have a sliding fit into the spar tubes. Do not hammer the blade into the spar tube as you could damage the blade or the gear motor bearings.

Gentle twisting should be sufficient to position the blades properly.

- ⚠ The blades must be installed with the aluminum blade extensions hanging below the bottom of the fan hub as shown.
- ⚠ With a 3/8" socket wrench, insert and tighten the (16) ¼" serrated bolts to 10 ft-lb torque. Using a 3/16" Allen key, tighten the (8) blade collars until firmly snug. Tighten blade bolts by hand prior to using a power tool. There is a torque spec for the collar.

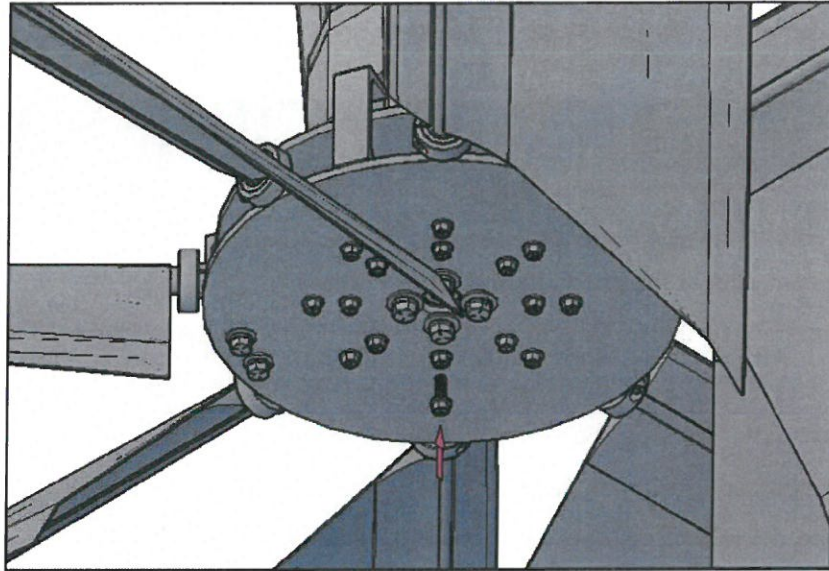

Figure 12 – Serrated washer head bolt installation

□ STEP 8

First Time Full Startup & Operation

- Set speed to zero before start up
- Make sure switch is off before initial start up
- Apply power to the fan controller at the distribution panel.
- Determine the preferred speed setting for operation and leave the potentiometer at that setting. (This may be a different setting during the warm months than it is during cooler months. Warm months could be faster to provide evaporative cooling for personnel. Cooler months could be slower to reduce heat stratification.)
- Place the ON-OFF switch in the "OFF" position.
- Disconnect power at the Power distribution panel.
- Once power is off, rotate the RED disconnect handle counter-clockwise to the OFF position and close the door of the enclosure.
- Turn the external handle to the "I" or "ON" position and reapply power at the distribution panel.
- The fan can now be controlled with the potentiometer and using the ON-OFF switch directly. Use the potentiometer to set the best speed, and the ON-OFF switch to start and stop the fan operation.

General Notes on Operation

- Do not disconnect power while fan is in motion; this will wear the gearbox
- Avoid blocking air flow to areas where people will benefit from it. This may involve moving obstructions or changing the orientation of obstructions to take maximum advantage of the airflow provided.
- Minimize interaction between the path of the fan blades and the direction of local area lighting. Multiple light sources will dramatically reduce the shadow casting of lights positioned above blades.
- In winter, maximum benefits are obtained by running the fan at a speed setting just below that which produces a noticeable breeze. In summer it is advantageous to run the fan at the highest speed which balances comfort and the work environment's airspace tolerance. Speed pot should be set to 5-15% for winter use

Fan Maintenance

Before attempting any maintenance, de-energize the fan and lockout the system to ensure that no one energizes the fan while maintenance is being performed.

To ensure the longevity of your Humongous Fan please conduct the following annually:

- Check the torque of all mounting fasteners. Do not loosen and re-torque the fasteners. Instead, check the torque in the tightening direction only with a calibrated torque wrench.
- Check the gear motor for oil leaks. If there are no noticeable leaks, no further action is required as the motor is lubricated for life.
- Check the controller and motor electrical power leads for tightness. This activity should be completed by a qualified electrician.
- Ensure that all safety cables are present and have been fastened with the least possible slack between linked components.
- Remove any dust accumulation to prevent the fan from becoming unbalanced.

Troubleshooting & Frequently Asked Questions (FAQ)



WARNING: Before attempting any maintenance, de-energize the fan and take steps (such as a lock out/tag out procedures) to ensure that no one energizes the fan while maintenance is being performed.

Problem: Fan wobbles noticeably while in use. **Solution:** This may be caused by a variety of problems, such as installing the fan in an open-sided structure, such as a barn, or installing the fan indoors near another air supply. In this case, it may be necessary to restrain the fan externally. Please call the factory for assistance.

Problem: Fan won't start. Ensure that the disconnect (if provided) is in the ON position or that power is supplied to the variable frequency drive if a controller is not provided. If that does not solve the problem, have a qualified electrician troubleshoot the circuit.

Problem: Excessive audible noise. Some noise is normal as with any fan. If you think the noise is excessive, please contact your Humongous fan representative or the factory for assistance.

Controls: The speed of the fan is controlled by the potentiometer located on the door of the enclosure. Turning it clockwise direction increases the speed of the fan. This may be left in the desired speed setting and just the ON -OFF switch can be used to turn the fan on. All the way clockwise is the full speed setting of the VFD.

The ON-OFF toggle switch determines whether the VFD is told to run or to stop. When moved to the ON position the Fan will ramp up to the speed setting on of the potentiometer. Positioning it to the OFF position will cause the fan to decelerate to stop.

The OFF position of the ON-OFF switch does not remove power from the controller. This must be done by turning the disconnect handle to the OFF position. If there is any reason to enter the controller cabinet, the power must be disconnected at the power source. Putting the disconnection handle to the OFF position will not suffice as power is still entering the cabinet.

Faults and Reset:

Faults: In normal operation, a fault will not occur. However, the VFD is constantly checking to make sure that it can protect itself from damaging situations such as over current conditions, high voltage or power loss and may fault

When a fault occurs in the VFD, the VFD trips and the Parameter Unit (PU) display on the front of the VFD inside the cabinet automatically changes to show the fault condition as an error code on the display. The fault display is located behind the door of the enclosure and may not be visible. Please contact the factory for assistance when assessing the source and solution to VFD faults.

Fault or alarm indication. When a fault or alarm occurs, the operation panel display automatically switches to the fault or alarm indication.

Resetting method. When a fault occurs, the VFD output is kept stopped. Unless reset, the VFD will not restart.

Reset. the VFD can be reset by performing any of the following operations. The VFD recovers about 1s after the reset is released.

- Operation 1: Using the operation panel, press to reset the inverter.

- Operation 2: Switch power OFF once. After the indicator of the operation panel turns OFF, switch it ON again.

When any fault occurs, take the appropriate corrective action, then reset the VFD, and resume operation. Not doing so may lead to the VFD fault and damage.

Failure to reach desired speed: The 1/2 HP VFD is designed to reach 60 Hz. The 1 1/2 HP VFD is designed to reach 55Hz. The 3 HP VFD is designed to reach 50 Hz. If this cannot be reached, please consult the factory after ensuring that the motor has the correct electrical connection. (A motor configured for 230v when connected to a 460v controller will cause the VFD to protect itself, by limiting the current.)

Any abnormal functioning should be noted, and corrective action taken immediately to remedy the situation in order to prevent damage to the fan.

Variable Frequency Drive (VFD) Fault Codes

Operation Panel Indication		Name	Refer to Page	
Error message	E---	E--	Faults history	244
	HOLD	HOLD	Operation panel lock	250
	LOCd	LOCd	Password locked	250
	Er 1 to Er 4	Er1 to 4	Parameter write error	250
	Err.	Err.	Inverter reset	251
Warnings	OL	OL	Stall prevention (overcurrent)	251
	oL	oL	Stall prevention (overvoltage)	251
	rb	RB	Regenerative brake prealarm	252
	TH	TH	Electronic thermal relay function prealarm	252
	PS	PS	PU stop	252
	MF	MT	Maintenance signal output	252
	UV	UV	Undervoltage	252
	SA	SA	Safety stop	253
Alarm	F _n	FN	Fan alarm	253
Fault	E _{OC} 1	E.OC1	Overcurrent trip during acceleration	253
	E _{OC} 2	E.OC2	Overcurrent trip during constant speed	253
	E _{OC} 3	E.OC3	Overcurrent trip during deceleration or stop	254
	E _{OV} 1	E.OV1	Regenerative overvoltage trip during acceleration	254
	E _{OV} 2	E.OV2	Regenerative overvoltage trip during constant speed	254
	E _{OV} 3	E.OV3	Regenerative overvoltage trip during deceleration or stop	254
	E _{TH}	E.THT	Inverter overload trip (electronic thermal relay function)	255
	E _{TH}	E.THM	Motor overload trip (electronic thermal relay function)	255
	E _{FI}	E.FIN	Fin overheat	255

Operation Panel Indication		Name	Refer to Page
E _{ILF}	E.ILF *	Input phase loss	256
E _{OLT}	E.OLT	Stall prevention	256
E. bE	E. BE	Brake transistor alarm detection	256
E. GF	E.GF	Output side earth (ground) fault overcurrent at start	256
E. LF	E.LF	Output phase loss	256
E _{OHT}	E.OHT	External thermal relay operation	257
E _{PTC}	E.PTC+	PTC thermistor operation	257
E. PE	E.PE	Parameter storage device fault	257
E _{PUE}	E.PUE	PU disconnection	257
E _{RET}	E.RET	Retry count excess	257
E. S ₁	E.S ₁ / E.CPU	CPU fault	258
E _{CDO}	E.CDO+	Output current detection value exceeded	258
E _{IOH}	E.IOH *	Inrush current limit circuit fault	258
E _{AIE}	E.AIE *	Analog input fault	258
E _{SAF}	E.SAF *	Safety circuit fault	258

* If a fault occurs when using with the FR-PU04, "Fault 14" is displayed on the FR-PU04.

Warranty Information

The following warranty shall apply to the various components of the Humongous Fan:

Blades, Fan Hub and Frame	5 Years
Beam Mounting Kit	5 Years (Parts Only)
Gear Motor.....	5 Years
Controller and VFD.....	5 years (Parts Only)

The warranty period shall commence at the date of shipment.

The Humongous Fan Company warranty is limited to repair and replacement of failed components during the warranty period. The Humongous Fan Company will not pay liquidated damages for loss of production or productivity potentially associated with a Humongous Fan under warranty.

The Humongous Fan Company does not warrant that the fan will supply a certain amount of air since airflow is highly dependent on building and mounting geometry and the presence of obstacles at floor level.

The following actions and conditions will cause the warranty to become void:

1. Failure to install the fan properly, including, but not limited to:
2. Failure to follow the appropriate national and local building and electrical codes.
3. Failure to follow the procedures in this installation manual.
4. Substitution of non-approved mounting hardware. Any deviation in mounting must be approved in writing by the Humongous Fan Company.
5. Any modification of the fan not listed in this document, including mechanical and electrical components. Any changing of software settings associated with the power electronics provided by the Humongous Fan company.
6. Incorrect voltage supply.
7. Any misuse or abuse, including the introduction of foreign objects.
8. Acts of God or other accidents.
9. Running the fan at a greater frequency than listed in for the corresponding fan models; 60 Hz (1/2 HP model), 55 Hz (1 ½ HP model), and 50Hz (3 HP model).
10. Failure to perform maintenance as directed in this manual and any other documentation provided by the Humongous Fan Company.
11. Any consequential damages sustained as a result of a failure to follow these warranty exclusions.

Humongous Fan reserves the sole right to determine whether or not a component has failed as a result of a warrantable design, manufacturing, or material defect or as a result of a warranty exclusion. Humongous Fan will determine the appropriateness of all remedies and repairs.

This is the only warranty associated with Humongous Fan products. This warranty supersedes any other warranty or statement by any person.

This page is intentionally left blank.